

VST-36/40/47/52-I

Insulated Articulated/Telescopic Aerial Device

WORKING HEIGHT: Up to 56 ft 6 in (17.2 m)

HORIZONTAL REACH: 30 ft 9 in (9.4 m)

PLATFORM CAPACITY: Up to 600 lbs (272 kg)

JIB CAPACITY (Optional): Up to 1000 lbs (454 kg)



VST-47-I shown with Material Handling option.

VERSALIFT

VERSALIFT is a leading global manufacturer of bucket trucks, digger derricks, cable placers and other specialty equipment for use in the power generation, transmission and distribution, investor-owned utility, telecommunications, bridge inspection, light and sign, and forestry industries. Providing equipment sales, service, training, warranty and financing to government agencies, corporations, contractors, co-ops and municipalities through its global network of facilities and distributors, the company employs more than 900 employees worldwide.

VST-36/40/47/52-I



Insulated Articulated/Telescopic Aerial Device

GENERAL SPECIFICATIONS:

	VST-36-I	VST-40-I	VST-47-I	VST-52-I
Horizontal Reach	26 ft 2 in (8.0 m)	30 ft 2 in (9.2 m)	30 ft 9 in (9.4 m)	30 ft 4 in (9.2 m)
Max Platform Capacity	600 lbs (272 kg)	600 lbs (272 kg)	600 lbs (272 kg)	600 lbs (272 kg)
Inner Boom Extension	79 in (2.0 m)	103 in (2.6 m)	103 in (2.6 m)	53 in (1.35 m)
Outter/Inner Boom Articulation	-25° to +85°	-25° to +85°	-25° to +85°	-25° to +85°
Lower Boom Articulation	0° to +87°	0° to +87°	0° to +84°	0° to +84°
Rotation	360° Continuous	360° Continuous	360° Continuous	360° Continuous

WITH STANDARD PEDESTAL:

Ht. to Bottom of Platform	36 ft 4 in (11.1 m)	40 ft 4 in (12.3 m)	46 ft 10 in (14.3 m)	51 ft 6 in (15.7 m)
Working Height	41 ft 4 in (12.6 m)	45 ft 4 in (13.8 m)	51 ft 10 in (15.8 m)	56 ft 6 in (17.2 m)
Stowed Travel Height	10 ft 6 in (3.2 m)	10 ft 6 in (3.2 m)	11 ft 0 in (3.4 m)	11 ft 6 in (3.5 m)
Weight of Lift	3200 lbs (1450 kg)	3300 lbs (1495 kg)	3600 lbs (1630 kg)	3800 lbs (1725 kg)

INSULATION GAP:

Upper Boom Fully Retracted	46 in (1.2 m)	46 in (1.2 m)	52 in (1.3 m)	52 in (1.3 m)
Upper Boom (Extended 12+ inches)	46 in (1.2 m)	46 in (1.2 m)	64 in (1.6 m)	64 in (1.6 m)
Lower Boom	12 in (305 mm)	12 in (305 mm)	12 in (305 mm)	12 in (305 mm)

HYDRAULIC SYSTEM:

Operating Pressure	3000 psi (206 bar)
Flow Rate	6 gpm (22.7 lpm)
Filtration	10 micron return 100 mesh suction
System Type	Open Center

OPTIONS:

- Auxillary Outriggers
- Second Set of Tool Power Ports
- Platform Elevator
- Various Pedestal Heights
- Automatic Boom Latch
- Backup 12-Volt Pump
- Hydraulic Jib/Winch (Reduces Platform Capacity 100 lbs)
- Jib up to 1000 lb (454 kg) capacity

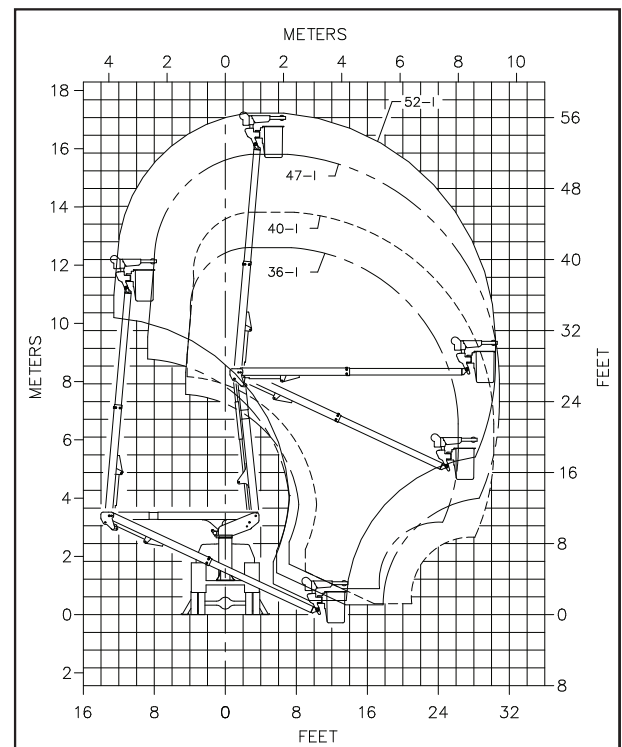

Note: Specifications on units may vary or change without prior notifications due to option selections.