

HIAB X-CL 6



HIAB X-CL 6 BASIC DATA

BASIC DATA	X-CL 6B-1	X-CL 6B-2
Lifting capacity (kNm)	48	45
Lifting capacity (tm)	4.9	4.6
Outreach - lifting capacity, standard (m-kg)	2.3 - 2 180 3.8 - 1 340 5.4 - 940	2.7 - 1 820 3.8 - 1 260 5.4 - 860 7.2 - 640
Outreach - lifting capacity, manual extensions (m-kg)	7.2 - 640 9.1 - 460	9.1 - 440
Hydraulic outreach, standard (m)	5.3	7.3
Hydraulic boom extension (m)	1.7	3.5
Outreach, manual extensions (m)	9.3	9.3
Lifting height above installation level, hydr/man (m)	7.7	9.6
Rec. oil flow (l/min)	25 - 30	25 - 30
Working pressure (Mpa)	24	24
Oil in tank (l)	35 - 65	35 - 65
Tank capacity (l)	40 - 75	40 - 75
Slewing angle (°)	410	410
Max slope viable at full capacity (°)	5	5
Slewing torque, gross (kNm)	7.7	7.7
Slewing speed (°/s)	15	15
Lifting speed at standard hydraulic outreach (m/s)	1.0	1.4
Height in folded position (mm)	1 900	1 900
Width in folded position (mm)	2 075	2 160
Install space required with hose and pipe kit (mm)	655	655
Crane in standard version without stabiliser system (kg)	730	810
Frame attachments (kg)	28 - 30	28 - 30
Stabiliser system equipment (kg)	105 - 160	105 - 160

This table show one example of a model, and represents some of all options available. With the opportunity to configure your crane, we can provide you with a crane perfectly tailored to your needs.

Please contact your local dealer for more information and the exact data on the variety of options we can offer.

Hiab X-CL 6B-2

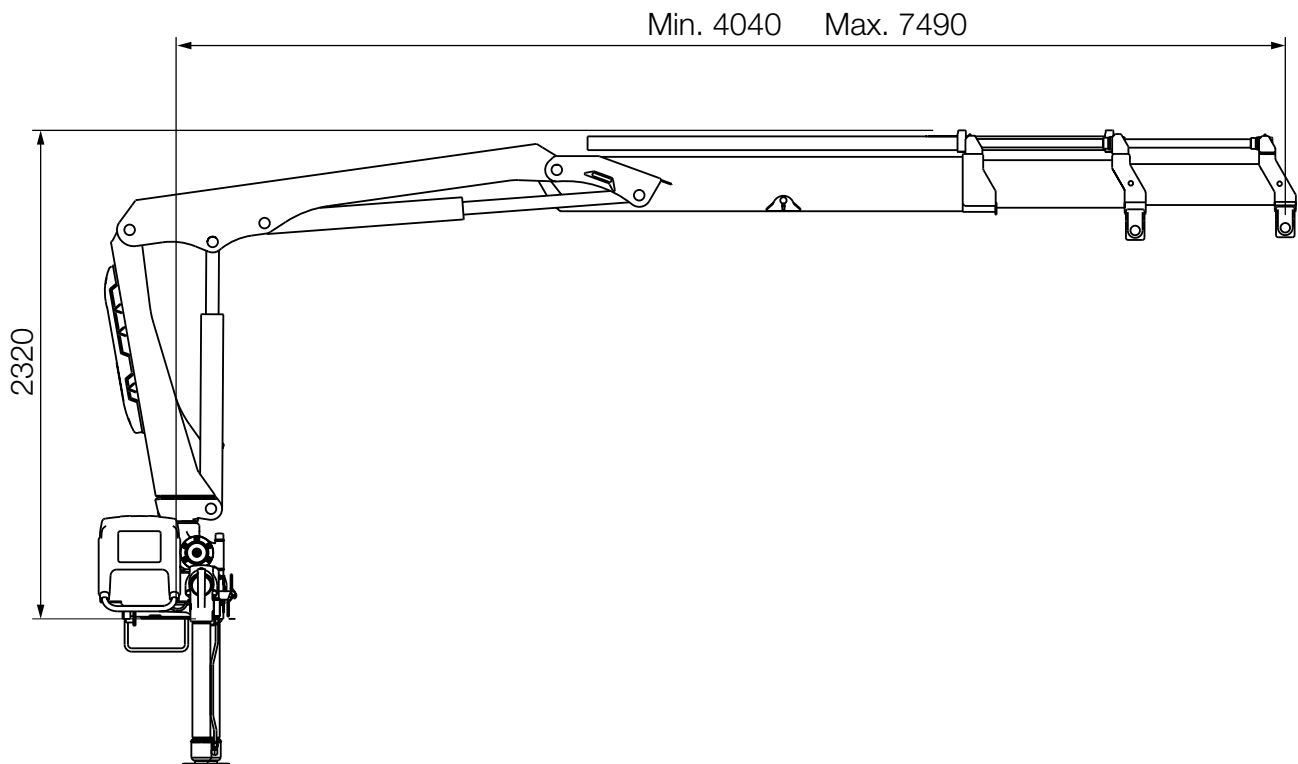
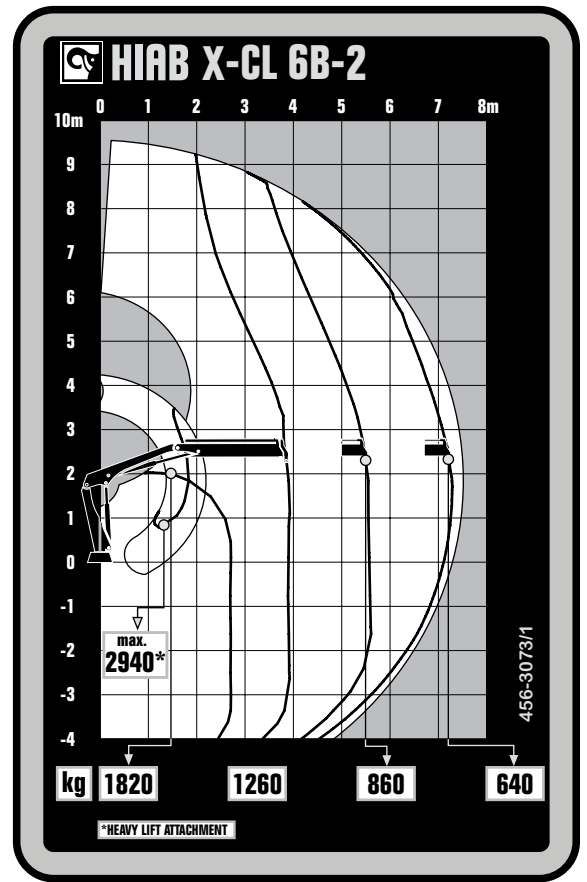
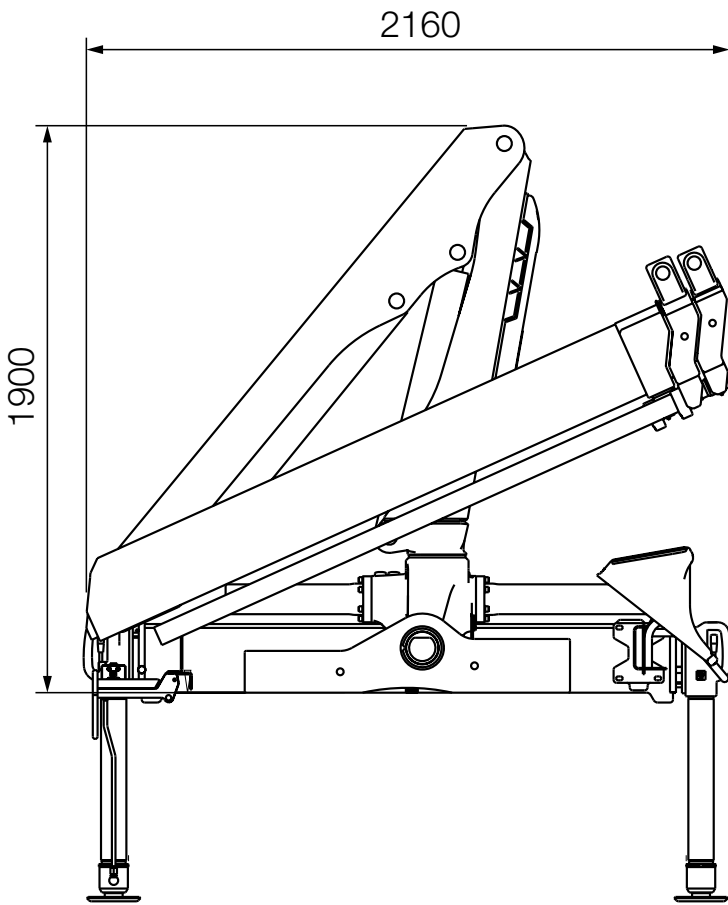

BUILT TO PERFORM

Hiab is the world's leading provider of on-road load handling equipment. Customer satisfaction is the first priority for us. Hiab's product range includes HIAB loader cranes, JONSERED recycling and forestry cranes, LOGLIFT forestry cranes, MOFFETT truck mounted forklifts and MULTILIFT demountables, as well as DEL, WALTCO and ZEPRO tail lifts.

hiab.com

Hiab is part of Cargotec.

cargotec.com



© BD-XCL6-EN-WW_190108



hiab.com